

# 4/5/6/7kW Grid-tied PV Inverter for North America

The CPS SCE series PV inverters are designed for the North America market and are compliant with UL and CSA standards. With advanced transformerless technology, the products reach a 97.5% maximum efficiency, providing competitive, long-term electricity generation benefits.

The enclosures are NEMA 3R rated for general outdoor application. Designed for high reliability and easy installation, CPS SCE series are the ideal choice for residential rooftop applications.



CPS SCE4/5/6/7KTL-O/US

### Efficiency Curve

CPS SCE5KTL-O/US @ 240Vac

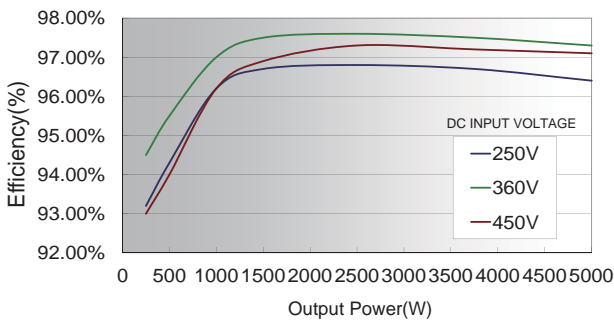

### High Efficiency

- Max. efficiency of 97.5%, CEC efficiency of 97%
- High speed and precise MPPT algorithm

### High Reliability

- Standard warranty: 10 years
- Design for reliability
- Comprehensive protection functions
- GFCI embedded
- Comply with UL1741(2010), CSA C22.2 No.107.1-01, IEEE1547(2003), IEEE1547.1(2005)

### Broad Adaptability

- Wide MPPT range enables flexible stringing
- NEMA 3R, outdoor application
- Quick installation and easy maintenance
- Lead-free, RoHS complied
- Integrated DC and AC disconnect
- Internal DC and AC fuse

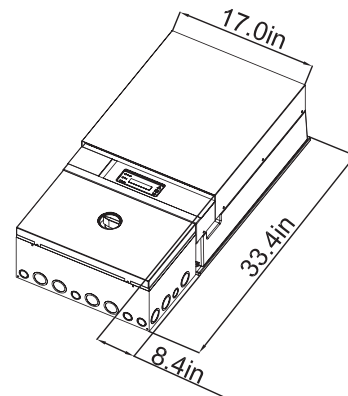

Dimensions



Model Name	CPS SCE4KTL-O/US	CPS SCE5KTL-O/US	CPS SCE6KTL-O/US	CPS SCE7KTL-O/US
<b>DC Input</b>				
Max. PV Power	4.8kW	6kW	7.2kW	8.4kW
Nominal DC Input Power	4kW	5kW	6kW	7kW
Max. DC Input Voltage	600Vdc			
Operating DC Input Voltage Range	100-515Vdc			
Start-up DC Input Voltage	150Vdc			
Nominal DC Input Voltage	360Vdc			
Number of MPP Trackers	1			
Number of DC Input Pairs	4			
MPPT Voltage Range	225-500Vdc	200-500Vdc	200-500Vdc	200-500Vdc
Max. Input Current (Imp)	19A	26A	32A	37A
Max. Input Current per String	20A			
Max. Short Circuit Current (Isc)	24A	32.5A	40A	46.5A
DC Disconnection Type	Switch			
<b>AC Output</b>				
Nominal AC Power @ 208Vac	3.8kW	4.6kW	6kW	7kW
Nominal AC Power @ 240Vac & 277Vac	4kW	5kW	6kW	7kW
Max. AC Power @ 208Vac	3.8kW	4.6kW	6kW	7kW
Max. AC Power @ 240Vac & 277Vac	4kW	5kW	6kW	7kW
Rated Output Voltage	240V / Split phase			
Output Voltage Range @ 208Vac	186-225Vac			
Output Voltage Range @ 240Vac	215-260Vac			
Output Voltage Range @ 277Vac	248-300Vac			
Grid Connection Type	Single phase / 240V Split phase			
Nominal AC Current @ 208Vac	18.3A	22.1A	28.9A	33.7A
Nominal AC Current @ 240Vac	16.7A	20.8A	25 A	29.2A
Nominal AC Current @ 277Vac	14.4A	18.1A	21.7A	25.3A
Max. AC Current @ 208Vac System	18.5A	22.5A	30A	35A
Max. AC Current @ 240Vac System	18.5A	22.5A	28.5A	33.2A
Max. AC Current @ 277Vac System	16.4A	20.5A	24.6A	28.7A
Rated Output Frequency	60Hz			
Output Frequency Range	59.3-60.5Hz			
Power Factor	>0.99			
Current THD	<3%			
AC Disconnection Type	Switch			
<b>System</b>				
Topology	Transformerless			
Max. Efficiency	97.5%			
CEC Efficiency	97.0%			
Stand-by / Night Consumption	<7W / <0.2W			
<b>Environment</b>				
Protection Degree	NEMA 3R			
Cooling	Variable speed cooling fans			
Operating Temperature Range	-13°F to +122°F / -25°C to +50°C			
Operating Humidity	0-95%, non-condensing			
Operating Altitude	6562ft / 2000m without derating			
<b>Display and Communication</b>				
Display	LCD + LED			
Communication	RS232, RS485			
<b>Mechanical Data</b>				
Dimensions (WxHxD)	17.0x33.4x8.4in / 434x850x213mm			
Weight	86lbs / 39kg	90lbs / 41kg	101lbs / 46kg	101lbs / 46kg
<b>Safety</b>				
Grid Trip Points	Meet fixed voltage and frequency settings for <30kW systems, per IEEE1547 section 4.2.3 and 4.2.4			
Safety and EMC Standard	UL1741: 2010, CSA C22.2 No.107.1-01, FCC PART15 Class B			
Grid Standard	IEEE1547: 2003, IEEE1547.1: 2005			

Information furnished is believed to be accurate and reliable. However, Chint Power Systems assumes no responsibility for the consequences of use of such information nor for any infringement of patents or other rights of third parties which may result from its use. No license is granted by implication or otherwise under any patent or parent rights of Chint Power Systems. Specifications mentioned in this publication are subject to change without notice. This publication supersedes and replaces all information previously supplied.